

**RIDGID
FINISH STAPLER
MODEL NO. R150FSA
REPAIR SHEET**

**RIDGID
AGRAFEUSE DE FINITION
NO. DE MODÈLE R150FSA
FEUILLE DE RÉPARATION**

**RIDGID
GRAPADORA DE ACABADO
MODELO R150FSA
LISTAS DE PIEZAS DE REPUESTO**

RIDGID R150FSA

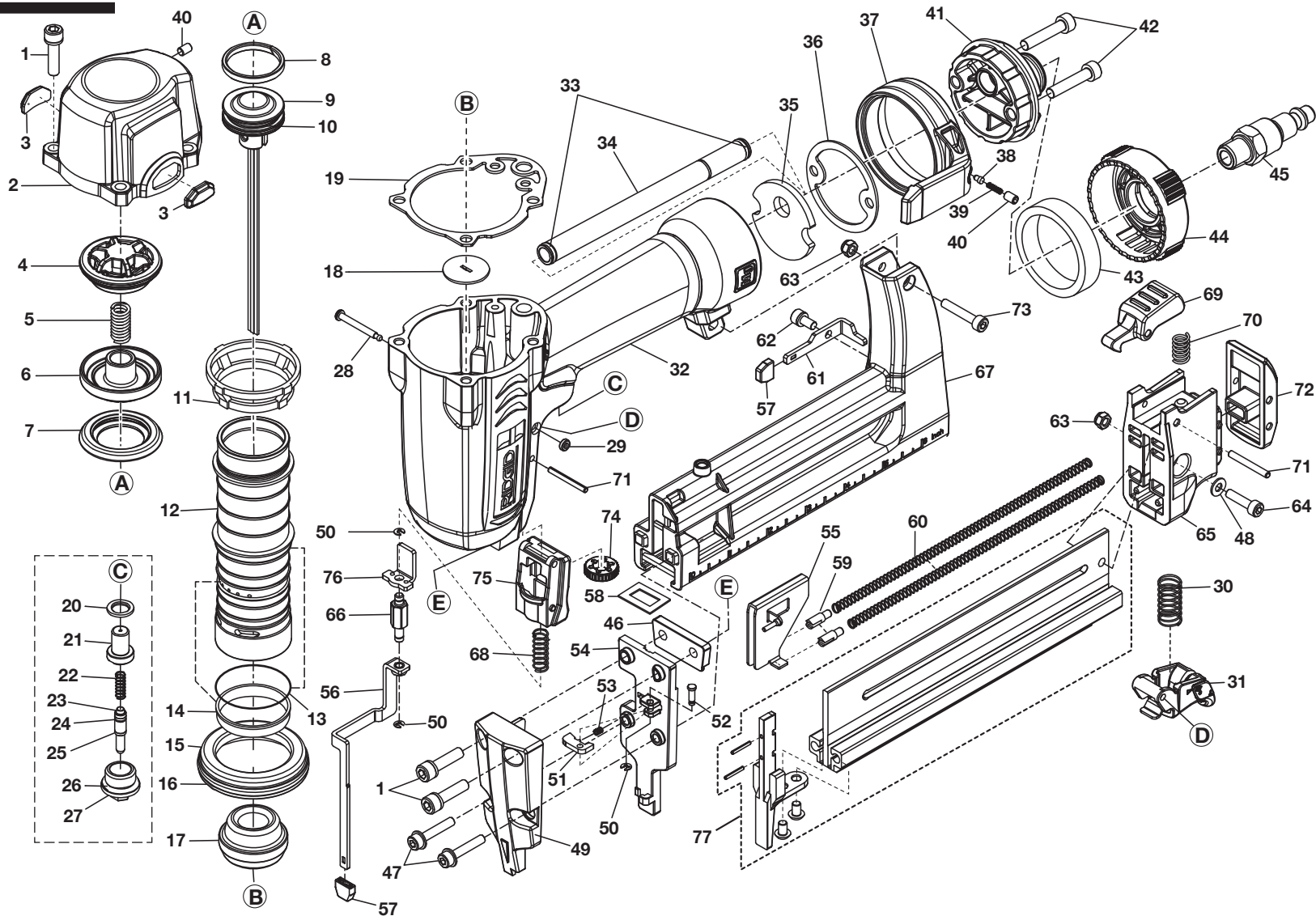

⚠ DANGER: Do not use oxygen, combustible gases, or bottled gases as a power source for this tool. The tool will explode and cause death or serious injury.

⚠ DANGER : Ne pas utiliser de l'oxygène ou des gaz combustibles ou en bouteille pour alimenter l'outil. L'outil exploserait, causant des blessures graves ou mortelles.

⚠ PELIGRO: No utilice oxígeno, gases combustibles ni gases embotellados como fuente de energía para esta herramienta. La herramienta explotará y causará la muerte o lesiones serias.

⚠ WARNING: Disconnect the tool from the air supply before performing maintenance. Failure to do so could result in serious personal injury.

⚠ AVERTISSEMENT : Débrancher l'outil de la source d'air avant tout entretien. Ne pas prendre cette précaution peut entraîner des blessures graves.

⚠ ADVERTENCIA: Desconecte la herramienta del suministro de aire antes de efectuar tareas de mantenimiento. La inobservancia de esta advertencia puede causar lesiones serias.



R150FSA Finish Stapler

KEY	P/N	DESCRIPTION	QTY	KEY	P/N	DESCRIPTION	QTY	KEY	P/N	DESCRIPTION	QTY
1	079001001001	BOLT ASSY (M5 x 0.8-20 + Dp5) ..	6	42	079001001043	BOLT (HEX SOC. HD.) (M5 x 0.8-25) ..	2	76	079001001078	WORK CONTACT ELEMENT	1
2	079001001002	CAP	1	43	079001001044	MUFFLER	1	77	079001001700	MAGAZINE AND DRIVER GUIDE ASSEMBLY	1
3	079001001003	GUIDE COVER	2	44	079001001045	GUIDE PLATE	1	78	079001001082	OVERHAUL KIT – NOT SHOWN (INCL. KEY NO. 4, 7, 8, 13, 14, 16, 17, 19, 20-27, AND 29, PLUS LUBRICANT)	1
4	079001001004	COLLAR	1	45	079001001046	AIR PLUG (NPT 1/4 in.-18)	1	79	079001001083	DRIVER MAINTENANCE KIT – NOT SHOWN (INCL. KEY NO. 8-10, 17 AND 19, PLUS LUBRICANT)	1
5	079001001005	COMPRESSION SPRING	1	46	079001001047	GASKET	1	80	079001001084	DRIVER ASSEMBLY – NOT SHOWN (INCL. KEY NO. 8-10 PLUS LUBRICANT)	1
6	079001001006	HD.VALVE PISTON	1	47	079001001048	BOLT W/FLAT WASHER (M4 x 0.7-22 + Dp9 x t0.8) (3M23)	2	81	079001001085	TRIGGER ASSEMBLY – NOT SHOWN (INCL. KEY NO. 20-27) ...	1
7	079001001007	SEAL	1	48	079001001049	FLAT WASHER (D9 x d4.2 x t0.8)	1	82	079001001099	WRENCH KIT – NOT SHOWN (INCL. 3 mm AND 4 mm HEX KEYS)	1
8	079001001008	PISTON RING	1	49	079001001050	RELIEF PLATE	1	83	079001001086	CASE – NOT SHOWN	1
9	079001001009	DRIVER UNIT	1	50	079001001051	E-RING (ETW2)	3	84	079001001088	GLASSES – NOT SHOWN	1
10	079001001010	O-RING (23 x 2) (2023)	1	51	079001001052	WORK CONTACT ELEMENT DAMPER	1	85	079001001096	WARNING LABEL – NOT SHOWN	1
11	079001001011	COLLAR	1	52	079001001053	FIXED PIN	1	86	079001001095	DATA LABEL – NOT SHOWN	1
12	079001001012	CYLINDER	1	53	079001001054	POSITIONING SPRING	1	87	079001001092	LOGO LABEL – NOT SHOWN	2
13	079001001013	O-RING (32 x 2) (2032)	1	54	079001001055	DRIVER GUIDE COVER	1	88	079001001093	MODEL LABEL (TOOL CASE)	1
14	079001001014	CYLINDER RING	1	55	079001001059	PUSHER UNIT	1	89	983000614	OPERATOR'S MANUAL – NOT SHOWN	1
15	079001001015	CYLINDER SPACER	1	56	079001001081	CONTACT MECHANISM A	1	90	983000614R	REPAIR SHEET – NOT SHOWN	1
16	079001001016	O-RING (47.5 x 2) (S48)	1	57	079001001090	NO MAR PAD	2	91	983000623	FASTENER GUIDE – NOT SHOWN	1
17	079001001017	BUMPER	1	58	079001001091	JOINT GUIDE	1	92	079001001102	TRIGGER WRAP LABEL – NOT SHOWN	1
18	079001001018	DRIVER GUIDE	1	59	079001001060	SHAFT	2	93	079001001103	HANG TAG – NOT SHOWN	1
19	079001001019	CYLINDER CAP SEAL	1	60	079001001061	PUSHER SPRING	2				
20	079001001020	SEAL	1	61	079001001062	STOPPER	1				
21	079001001021	TRIGGER VALVE HEAD	1	62	079001001063	BOLT ASSY (M4 x 0.7-08 + Dp4)	1				
22	079001001022	SPRING	1	63	079001001064	LOCK NUT (M4 x 0.7)	2				
23	079001001023	PLUNGER	1	64	079001001065	BOLT (HEX SOC. HD.) (M4 x 0.7-16)	1				
24	079001001024	O-RING (2.5 x 1.5) (S3)	1	65	079001001066	REAR PLATE	1				
25	079001001025	O-RING (2.5 x 1.5) (S3)	1	66	079001001079	ADJUST ROD UNIT	1				
26	079001001026	O-RING (13 x 2) (2013)	1	67	079001001105	MAGAZINE UNIT B W/INSERTS ..	1				
27	079001001027	PLUNGER CAP	1	68	079001001077	WORK CONTACT ELEMENT SPRING	1				
28	079001001028	TRIGGER PIVOT PIN	1	69	079001001070	LATCH	1				
29	079001001029	RETAINER	1	70	079001001071	LOCK SPRING	1				
30	079001001030	SPRING	1	71	079001001072	SPIRAL PINS (Dp3-24)	2				
31	079001001031	TRIGGER UNIT	1	72	079001001073	HOOD COVER	1				
32	079001001032	TOOL BODY UNIT	1	73	079001001074	BOLT (HEX SOC. HD.) (M4 x 0.7-25)	1				
33	079001001033	O-RING (7.5 x 1.5) (S8)	2	74	079001001075	ADJUST KNOB	1				
34	079001001034	LINK ROD	1	75	079001001076	WORK CONTACT ELEMENT GUIDE	1				
35	079001001036	FILTER	1								
36	079001001037	GASKET	1								
37	079001001038	SPRING RETAINER	1								
38	079001001039	POSITIONING SHAFT	1								
39	079001001040	POSITIONING SPRING	1								
40	079001001041	SCREW (HEX SOC. HD.) (M4 x 0.7-06)	2								
41	079001001042	END CAP (NPT 1/4 in.)	1								

04-13-07
(REV: 05)

